

CUSTOM SHOWER KIT INSTALLATION INSTRUCTIONS FOR BARRIER FREE APPLICATIONS

The Custom Shower Bases are designed to be installed directly on a rough floor and against the wall studs. The wall panels are to be installed (usually over sheetrock) with adhesive (See Fig. 1).

Materials Supplied by Taylor:

Custom Shower Base
3/8" x 4-1/2" trim pieces
Optional Ramp, 8" x 1-1/2" thick
Wall Panels, if applicable
Optional accessories
10 oz. Cartridges of RTV Silicone Adhesive
6 oz. Cartridge of Color Coordinating Silicone Sealant
"Perfect Bead" Tool / Instructions

Tools Required:

Caulking Gun
Belt Sander with 36 grit (coarse) belt
Coarse file or "Stanley Shurform"
Electric Drill with 1/4" bit
Saber Saw with 10 to 14 tooth per inch blade or
Carbide grit-edge blade
Knife, Compass, Pencil and Plastic Spoon

Materials Required:

Rubbing Alcohol or Lacquer Thinner
Paper Towels
Masking Tape

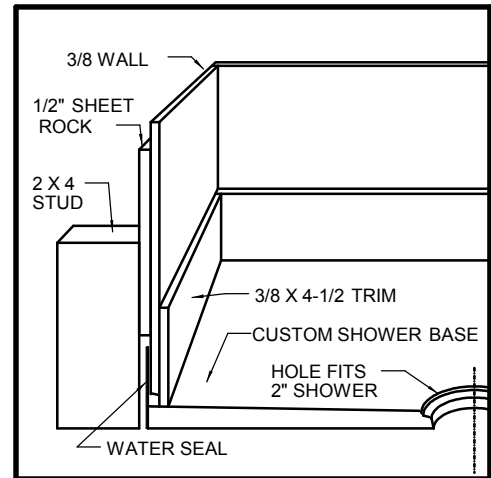

Fig. 1

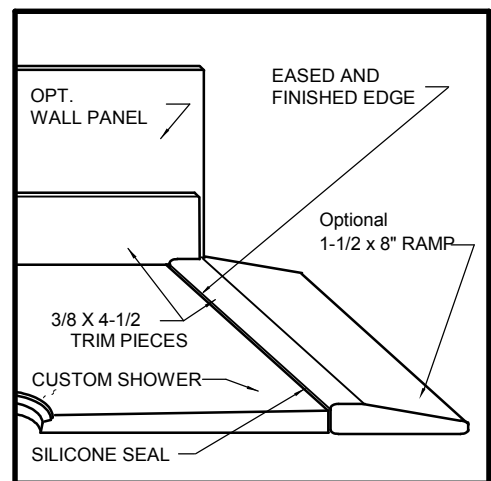

Fig. 2

- Step 1. Remove protective masking from panel edges and inspect for shipping damage. Check the size of the opening against the required rough-in dimensions. Check walls for plumb, squareness and flatness. Walls should be within 1/8" of true. Shim or trim opening, as required.
- Step 2. Finish all plumbing or electrical work inside the walls.
- Step 3. Locate, mark and cut a 6 - 7" diameter hole in the floor for the floor drain. Install drain plumbing in the floor and supply plumbing in the walls.
- Step 4. Install the drain hardware to the base and place the base into position (roughly 1/8" from the studs). Use a standard 2" shower drain available from plumbing suppliers and hardware stores. Note: The floor must be level to within 1/16" per 24". If the base is not properly leveled, there will be problems with the later installation of the wall panels and/or shower enclosures or doors. The base should be bedded in plaster or loose mortar to provide proper leveling and even load distribution across the entire surface.
- Step 5. Mark off the interior of the shower base and cut a piece of cardboard from the shipping carton and place it in the bottom to protect the base during installation.

- Step 6. Install 1/2" water-resistant sheetrock to the studs of the walls surrounding the base, leaving a 1/2" gap above the integral water seal (See Fig. 1) to prevent water damage to the wall should the sealant fail. The shower base is equipped with a 3-1/2" reinforced water seal around the perimeter of the base.
- Step 7. Install the Optional Entrance Ramp across the open side and check the height against the shower floor (See Fig. 2). It should be no more than 1/4" above or below the shower floor surface for ease of entry and exit. Shim or trim as may be required. Wipe down the floor and back side of the ramp with isopropyl alcohol and bond the ramp to the floor with the RTV Silicone Adhesive supplied.
- Step 8. Test fit the back wall panels. They should fit with a maximum clearance of 1/4" on each side. The back wall panel may be scribed and sanded to fit the slope of the shower base floor, however, it is not necessary as the trim pieces supplied will present a finished look. These trim pieces are to be scribed and sanded to fit the bottom of the shower and lap the bottom edge of the panels. A belt sander with a 36 grit belt works well. Clean the edges with solvent and wipe the dust from the back of the panel.
- Step 9. Quickly apply adhesive directly to the sheetrock in heavy 3/8" diameter beads (a tube of adhesive will do about 2 lineal feet of a 72" high panel). Beads should be placed within 3" of the panel perimeter, across the center and in a crisscross pattern. Place the panel in position spaced above the shower base by the thickness of a popsickle stick and press into the adhesive. This gap allows a full silicone seal to this edge which will better resist stress due to thermal expansion and contraction of the panels. Hold the panel in place with bracing until adhesive sets.
- Step 10. Place a side panel into position against the rear panel. The panel should fit within 1/8", if not, scribe and sand the unexposed edge to fit. If this panel is to be cut out for the valve, mark the location. Scribe a circle of the diameter required at each hole location. Drill a 1/4" diameter hole inside the circle and cut out the circle with a saber saw with a carbide grit-edge blade or a sharp 10 or 14 tooth per inch blade. Glue the panel as in "Step 9", except place an additional adhesive bead near the outside edge of the panel to provide support under the panel where the shower enclosure frame fastens to the wall.
- Step 11. Install the remaining wall panels in the same manner as Step 10.
- Step 12. Brace wall panels, as required, with scrap lumber. **CAUTION: DO NOT FORCE A PANEL TO FIT A BOWED WALL AS IT MAY BREAK**, furthermore, the resiliency of the panel can break the adhesive bond when the bracing is removed. Brace for 24 hours.
- Step 13. Install the remaining pieces of 3/8" x 4-1/2" trim. Scribe and sand to fit these pieces to the base so that their upper finished edges are even with the top of the entrance ramp. This will give a finished look, as well as, simplify the panel installation. Bond these trim pieces into position with silicone sealant. Wipe off any excess sealant.
- Step 14. Remove the bracing and clean the joints with solvent. Make sure the joint is clean as excess adhesive or other foreign material can cause the silicone sealant to discolor. Apply a bead of silicone to the interior vertical joints forcing the silicone deep into the joint. Tool the joint within 5 minutes with the supplied "Perfect Bead" tool. Now do the horizontal joints between the walls and the base. The excess silicone that is squeezed out by the tool can be cleaned up most easily by waiting until the silicone has "set" (about 30 minutes), then scrape the excess "firm" silicone from the panels with a plastic spoon (the plastic spoon will not scratch the gel-coated surface of the panels or base, do not use metal). Allow the silicone to cure for a day, install the shower enclosure and plumbing hardware and remove the protective panel coverings, and the job is finished.

NOTE:

If minor scratches occur during installation, refer to our "Care and Maintenance Instructions" or "Buffing Out Surface Scratches". Any adhesive residue can be removed with Lysol Tub and Tile Cleaner or paint thinner.